

HANDHELD ULTRASONIC DEPTH METER GUT775

Product Introduction

GUT775 ultrasonic detector is use to measure water depth in reservoirs, lakes, rivers, and other shallow water. Place the detector on the water surface or in the water, and the detector can calculate the current depth automatically via the principle of ultrasonic wave propagating in the water. The instrument uses international advanced technology and has perfect functions of depth measurement, controlment, data transmission and man-machine communication. It is a combination of ultrasonic sensor, ultrasonic servo circuit, temperature compensation sensor and compensation circuit unit.



Features

- ◆ Long using life
- ◆ High reliability and precision
- ◆ Convenient to use and operate
- ◆ Widely used in hydrographic surveying, hydropower plant, reservoir, shallow seas, lakes, rivers surveying and water environment monitoring

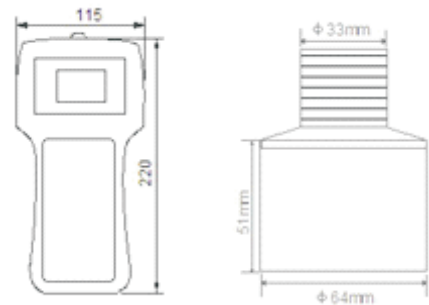

Indicators

Item	Specification
Range	100m (Customize)
Blind	≤500mm (according to range)
Draught	500mm
Accuracy	±0.5%F·S(default)
Output signal	4~20mA, RS485
Display mode	multi information and large screen LCD display
Keyboard	Five light touch buttons
Operation temperature	0~40 C (sensor) , -10 C~50 C (instrument)
Working power	The built-in rechargeable lithium batteries, intermittent standby time is about 6 hours, and equip special charger
Cable way	Instrument :standard connector, sensor down-lead: standard 10m
Application medium	Flesh water, sea water
Mounting model	Instrument: hand-held portable; Sensor: Thread
Defend grade	Sensor:IP68